

THIS DRAWING AND ALL THE INFORMATION THEREIN REMAINS THE PROPERTY OF ELEMENT NAVAL ARCHITECTURE. IT IS ISSUED ON THE CONDITION THAT, EXCEPT WITH WRITTEN PERMISSION, IT MUST NOT BE REPRODUCED, COPIED OR COMMUNICATED TO ANY OTHER PARTY. IT IS NOT SUITABLE FOR ANY PURPOSE AND IS ISSUED WITHOUT WARRANTY. DON'T COME CRYING BACK TO ME WHEN YOUR BOAT SINKS, SNAPS, CRACKLES AND OR POPS. IN FACT IF YOU USE THIS INFORMATION AT ALL YOU ARE CRAZY AND OR LOOPY. I ONLY PUT IT ON THE WEB BECAUSE IT IS PRETTY AND SO EVERYBODY ELSE CAN TELL ME HOW PRETTY IT IS.

ISSUE	DESCRIPTION	DATE	DRAWN
A	INITIAL RELEASE	17.6.14	MARKLA

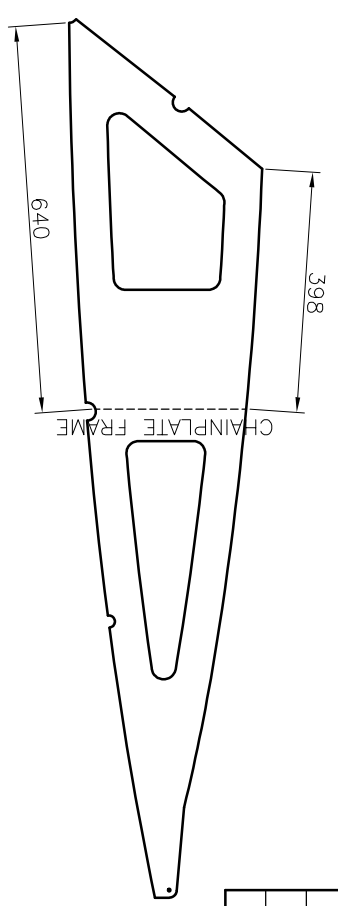

GL GIRDER ASSEMBLY

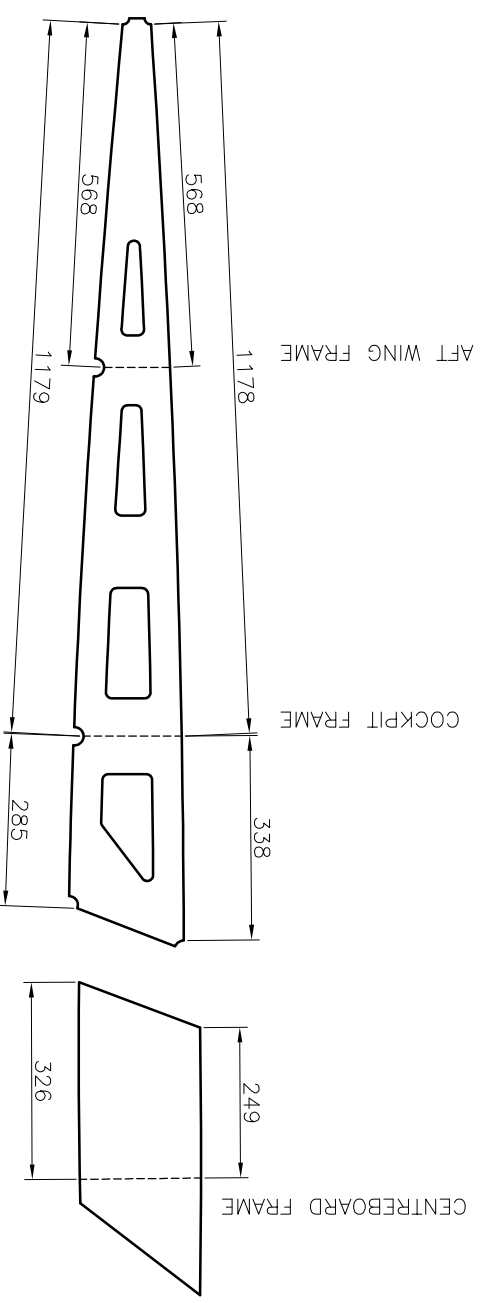
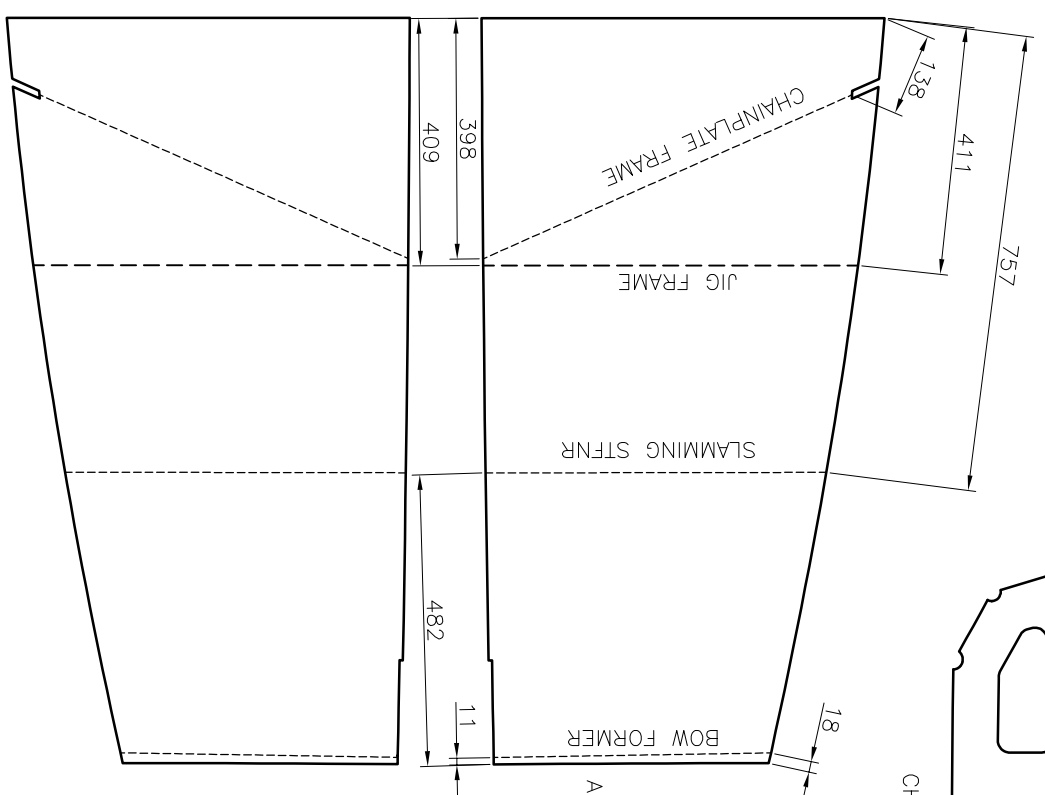
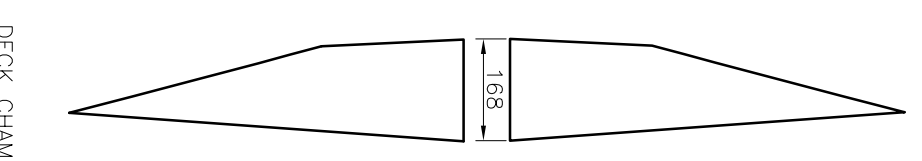
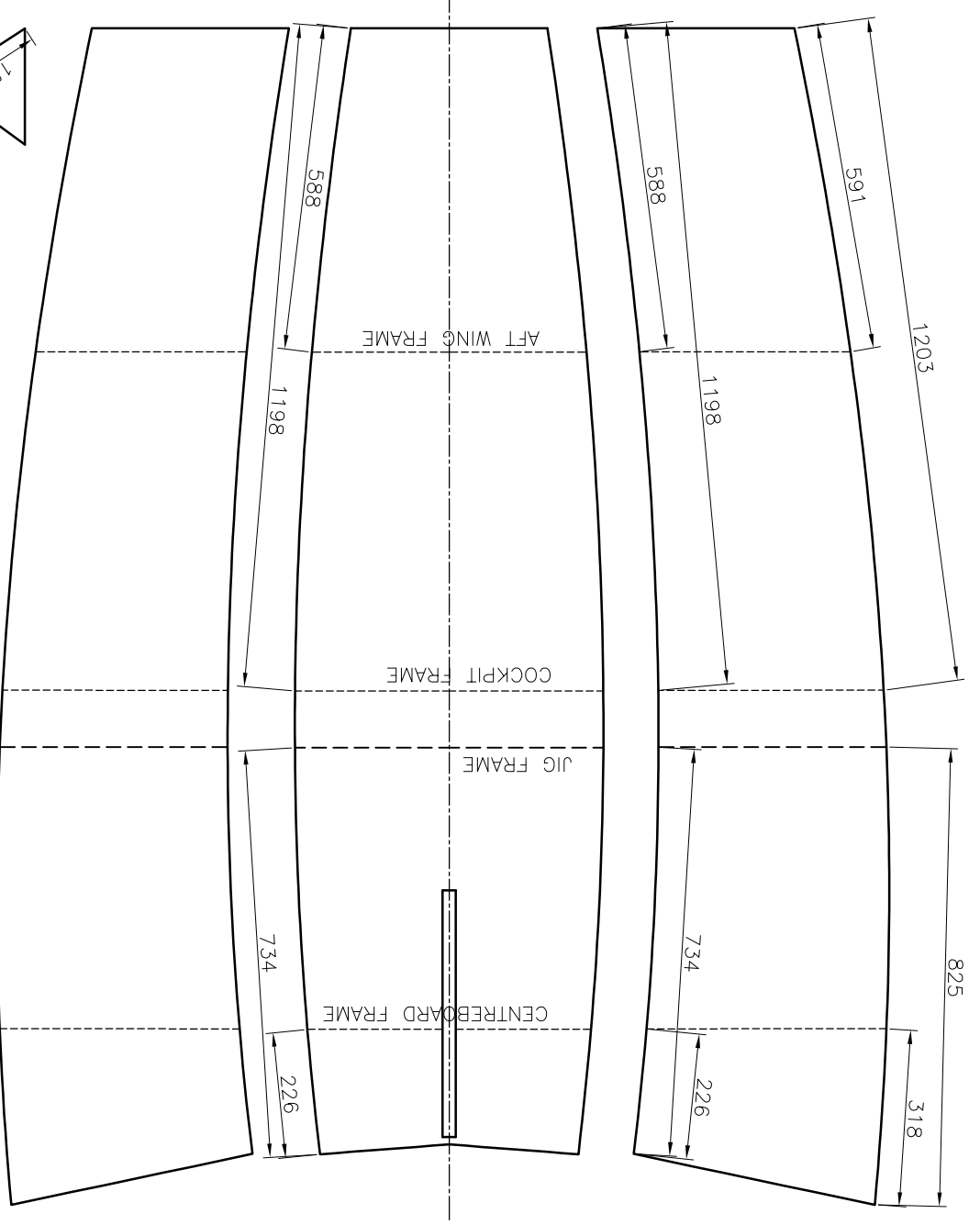
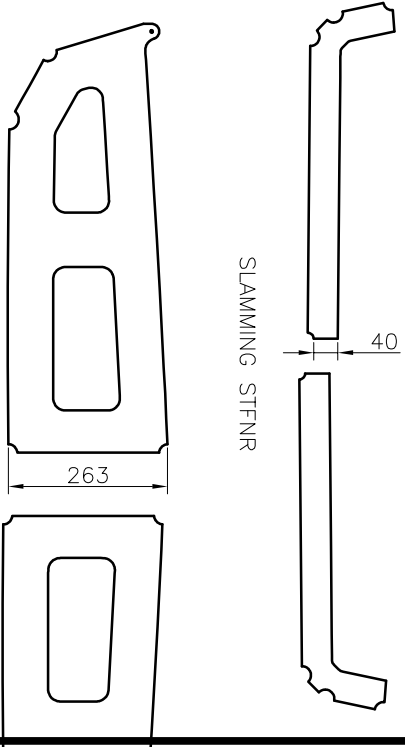
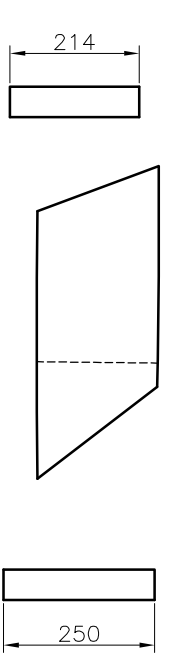

NOTE: ALL DIMENSIONS ARE TO THE CENTRE OF THE FRAMES. CARBON FRAMES AND JIG FRAMES DO NOT NECESSARILY LINE UP. ALL MARKINGS ARE FOR CARBON FRAMES UNLESS NOTED OTHERWISE

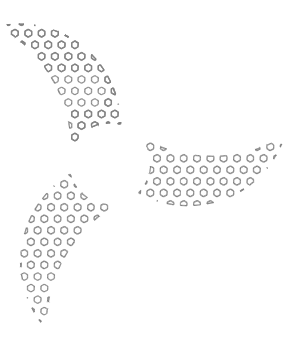

FOREDECK ASSEMBLY

ELEMENT

- NAVAL ARCHITECTURE -

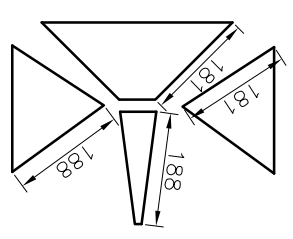

RUDDER POD

DECK ASSEMBLY

PROJECT: mSCOW	TITLE: PANEL MARKING (1 OF 2)	ISSUE: A
CLIENT: MARKLA	NUMBER: mSCOW-07	
DRAWN: MARKLA		
SCALE: 1:12.5		

THIS DRAWING AND ALL THE INFORMATION THEREIN REMAINS THE PROPERTY OF ELEMENT NAVAL ARCHITECTURE. IT IS ISSUED ON THE CONDITION THAT, EXCEPT WITH WRITTEN PERMISSION, IT MUST NOT BE REPRODUCED, COPIED OR COMMUNICATED TO ANY OTHER PARTY. IT IS NOT SUITABLE FOR ANY PURPOSE AND IS ISSUED WITHOUT WARRANTY. DON'T COME CRYING BACK TO ME WHEN YOUR BOAT'S SINKS, SNAPS, CRACKLES AND OR POPS. IN FACT IF YOU USE THIS INFORMATION AT ALL YOU ARE CRAZY AND OR LOOPY. I ONLY PUT IT ON THE WEB BECAUSE IT IS PRETTY AND SO EVERYBODY ELSE CAN TELL ME HOW PRETTY IT IS.

ISSUE	DESCRIPTION	DATE	DRAWN
A	INITIAL RELEASE	17.6.14	MARKLA

NOTE: ALL DIMENSIONS ARE TO THE CENTRE OF THE FRAMES. CARBON FRAMES AND JIG FRAMES DO NOT NECESSARILY LINE UP. ALL MARKINGS ARE FOR CARBON FRAMES UNLESS NOTED OTHERWISE

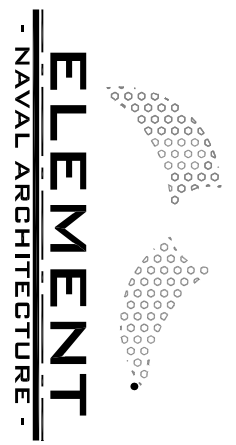
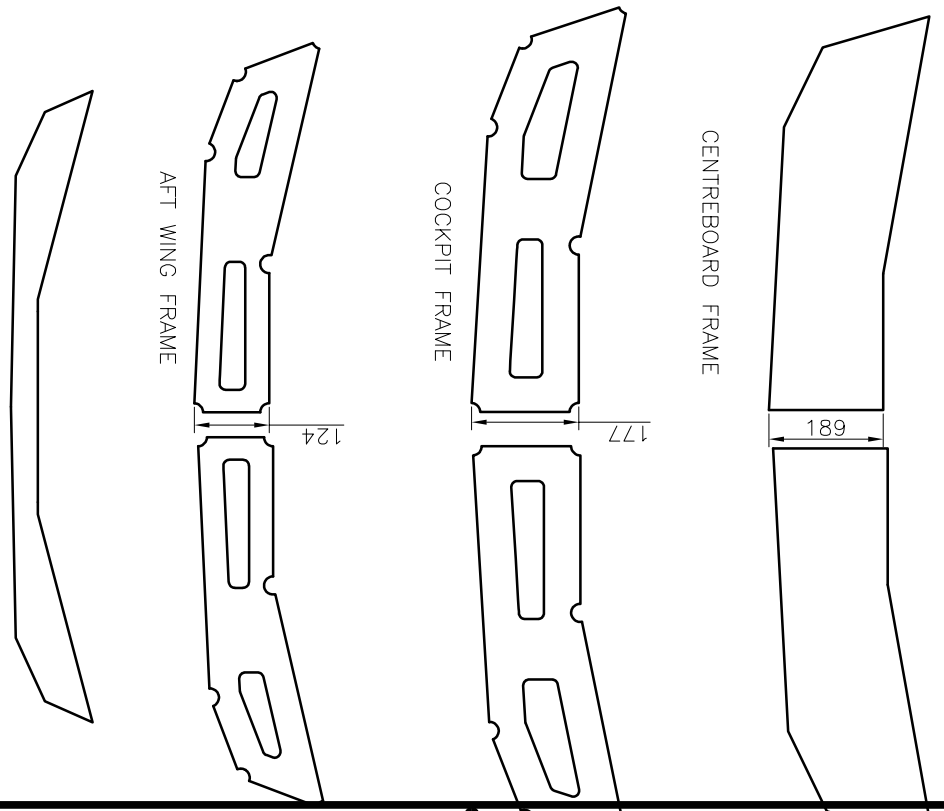
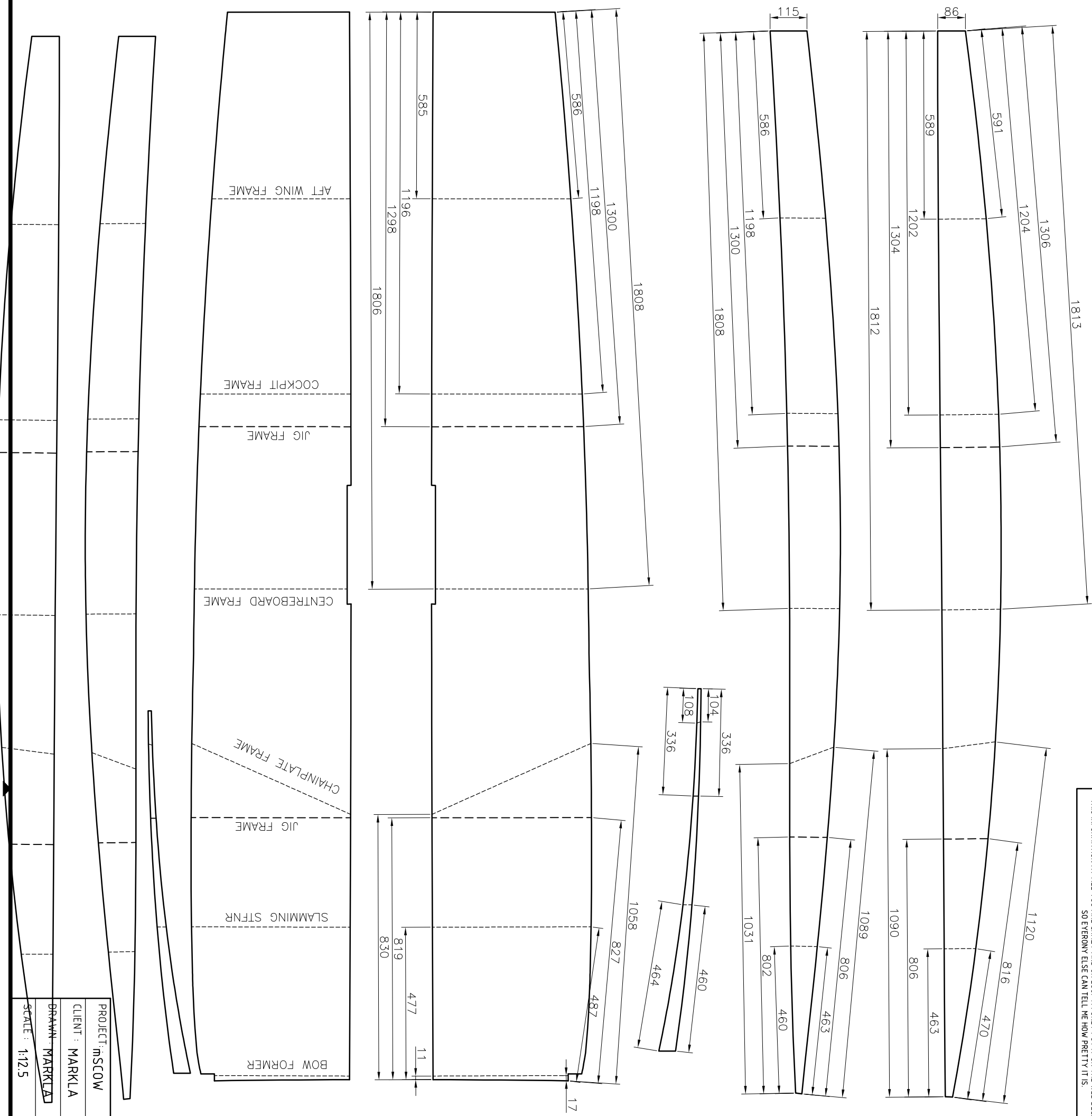

PROJECT: mSCOW	TITLE: PANEL MARKING (2 OF 2)	ISSUE: A
CLIENT: MARKLA	NUMBER: mSCOW-08	
DRAWN: MARKLA		
SCALE: 1:12.5		

